

SUPAVAC

SV60-H2 Next Gen Portable Slurry Pump - Horizontal

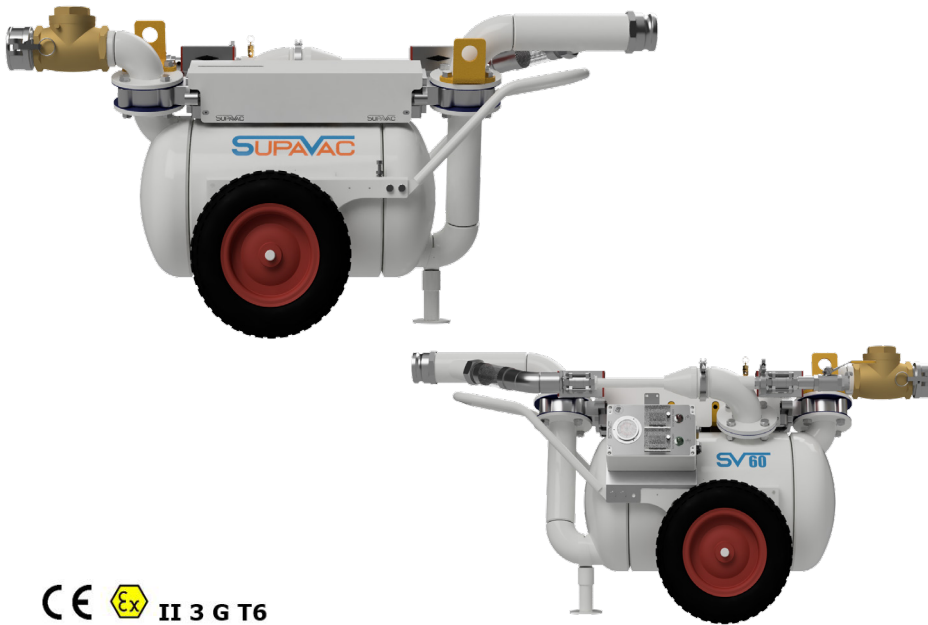

CE Ex II 3 G T6

Features

- ATEX Zone 2/CE conformity
- Next Generation Pneumatics
- 100% compressed air operation
- Multipurpose vacuum pump
- Intrinsically safe
- Fully automatic
- Versatile
- No internal moving components
- Minimal maintenance
- High vacuum and high airflow
- Recovers material from up to 50 metres (164 ft)
- Delivers up to 500 metres (1640 ft)

About

The SV60-H2 Portable Slurry Pump is a one man vacuum loading, pressure discharge pump capable of recovering and transferring up to 27 m³/hr (119USGPM) @ SG1.0.

The SV60 Portable Slurry Pump is 100% air powered and operated, generates up to 25" Hg+ of vacuum combined with high airflow which allows the unit to transfer materials ranging from mining slurries and oil sludge through to cementitious powders and grains.

The SV60-H2 Portable Slurry Pump is employed worldwide servicing farms, mines, drill rigs, municipal, industrial and construction sites.

Next Generation Pneumatic control box provides a more user friendly system with new countdown timers, indicators showing pump cycle, increased safety, usability & serviceability. Standardized across our SV30, SV60, SV60-V & SV110-V ranges, completely interchangeable & quick connectivity minimizing down time.

Applications

- Spillage recovery and transfer
- Sump cleaning and desilting
- Tank cleaning and sludge extraction
- Pneumatic excavation and dewatering
- WBM / OBM / Drill Cuttings transfer

New Options

- Next Generation Pneumatics Control box retro fit kits to upgrade existing pumps
- Low (adjustable) discharge pressure
- Reduced air consumption
- Spare parts kit includes quick change control box, reducing down time.

Technical Data

- Height 82 cm (31")
- Width 73 cm (29")
- Length 165 cm (65")
- Weight 168 kg (437 lb)
- Throughput capacity up to 27m³/hr (119USGM) @ SG1.0
- Air consumption 150cfm (71 L/sec) at minimum 85psi (6bar) to 100psi (7bar) at the pump
- Air supply connection 25mm (1")
- Up to 25" Hg+ (85kPa) vacuum
- Suction 75 mm (3") BSP/Type B camlock
- Discharge 75 mm (3") BSP/Type A camlock
- Handles solids to 50 mm (2")
- Carbon steel vessel
- Also available in 316 stainless materials of construction
- Skid mounted/roll frame weights/dimensions on request